



With bowl guard

Combination service units

Size 1

810.03 to 810.08

 G 1/4 (red.)
G 3/8 (red.)
G 1/2

 0.5 to 10 bar
0.5 to 16 bar

Characteristics

Type	810.03	810.04
Control range [bar]	0.5 to 10.0	0.5 to 16.0
Port	G 1/4 (red.)	
Type	810.05	810.06
Control range [bar]	0.5 to 10.0	0.5 to 16.0
Port	G 3/8 (red.)	
Type	810.07	810.08
Control range [bar]	0.5 to 10.0	0.5 to 16.0
Port	G 1/2 (red.)	
Pressure gauge port	G 1/4	
Type of construction	- Centrifugal filter Sintered filter element - Diaphragm pressure regulator with self-relieving design - Proportional lubricator	
Input pressure p_1	16 bar with plastic bowl 25 bar with metal bowl	
Input pressure p_1 with automatic drain	Min. 4 bar Max. 16 bar	
Control range p_2	0.5 to 10 bar, 0.5 to 16 bar Other control ranges on request	
Mounting position	Vertical, drain plug at bottom	
Mounting type	Bracket and two screws	
Medium temperature	0 to 50 °C (other temperature	
Ambient temperature	0 to 50 °C ranges on request)	
Filter rating	40 µm	
Bowl capacity	Filter: Max. 25 cm ³ condensate Oil-mist lubricator: 75 cm ³	
Condensate drain	Manual, semi-automatic Fully-automatic on request	
Weight [g]	1040	

Materials

Part	Material
Head piece (body)	Z 410
Spring bonnet	PA
Diaphragm	NBR-brass
Pressure spring	Steel
Valve cone	NBR-brass
O-ring 28x2	NBR
O-ring 56x2	NBR
Filter element	Bronze
Condensate bowl / oil bowl	Polycarbonate
Oil fill plug	POM-NBR
Sight dome	PA

Ordering information

Order example: 810.07 K

Port	
	See "Characteristics"
Options	
K	Plastic bowl
M	Metal bowl
S	Bowl guard

Please use the suffix »A« to order fully-automatic drain

Description

- Block design
- **Extremely compact design;** all devices combined in a single unit
- Pressure setting can be locked by pushing the knob down
- Pressure gauge Ø 50 mm included
- Filter rating acc. to ISO 4022, bubble point test
- Oil can be filled under pressure

Recommended oil

Special pneumatic oil 32

 Viscosity at 40 °C: 32 cSt [mm²/s]

Temperature range: -35 to +85 °C

Oil bowls made of plastic (polycarbonate) are corroded by additives, anti-freeze agents and synthetic oils. We therefore recommend using mineral oils from approx. 22 to 32 cSt or up to 68 cSt in conjunction with impact tools.

Metal bowls and metal sight domes should be used for all other oil grades.

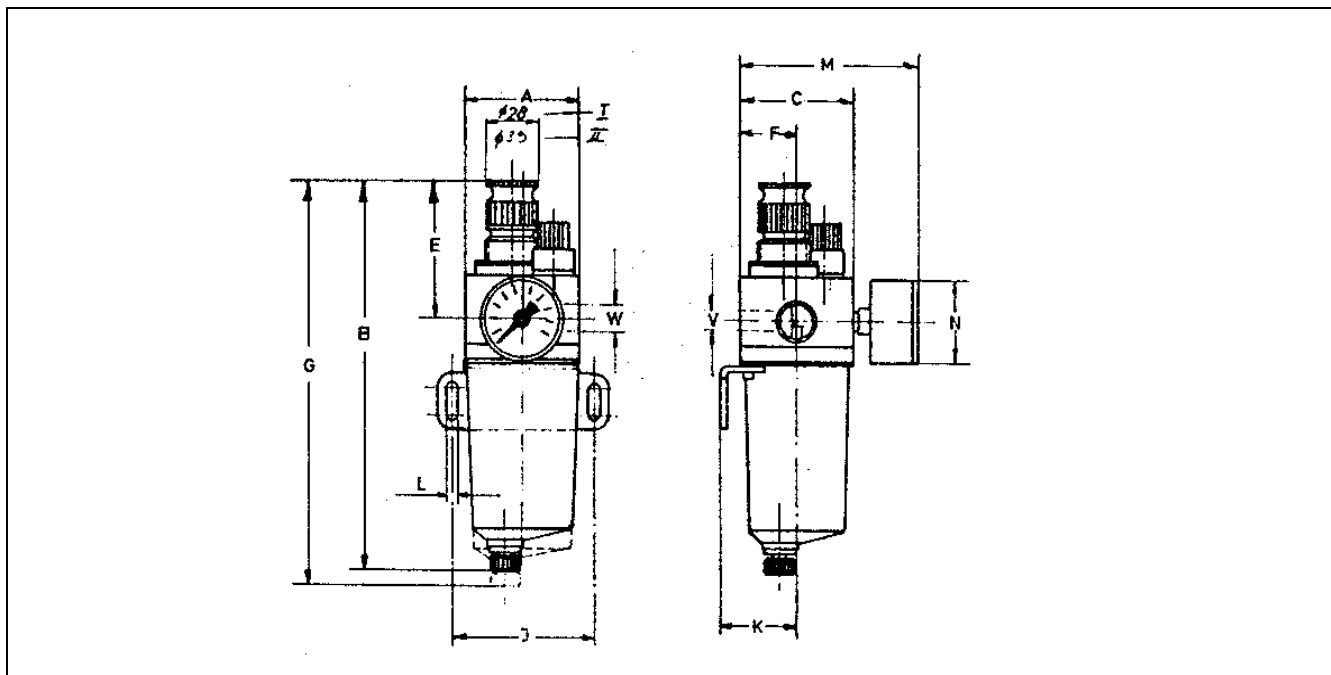
Dimensions [mm]

Port W	Dimensions					Maint. G	J	Mounting			Pressure gauge		
	A	B	C	E	F			K	L	V	N	M	
G 1/2 (G3/8 / 1/4 red.)	67.0	217.0	68.0	68.5	34.5	220.0	82.0	43.0	6.5	G 1/4	50.0	104.0	

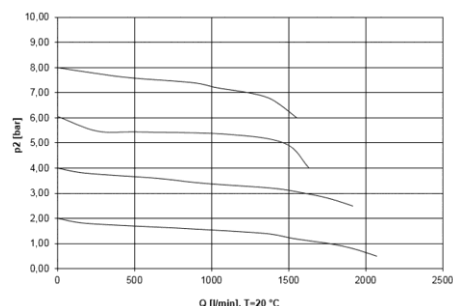
Flow characteristic $p_1 = 10 \text{ bar}$

Flow rates

Flow rates measured under normal conditions

Art. No.		810.03 X	810.04 X
		810.05 X	810.06 X
		810.07 X	810.08 X
Output pressure $p_2 = 6 \text{ [bar]}$	Q m ³ /h	91	91
Nominal flow ($\Delta p = 1 \text{ bar}$)	Q l/min	1520	1520

Lubricator operating limit

Input pressure p_1		1	2.5	4	6	10	16
Min. flow rate ($\Delta p = 1 \text{ bar}$)	QN m ³ /h	2	3.5	5	6.5	9.5	13

Accessories

Designation	Order No.
Mounting bracket with two screws, compl.	H 10
Plastic bowl	E 13810/24
Metal bowl	E 13810/24 M
Sight dome (metal)	1412.7.909
Sight dome (polycarbonate)	VZ 722
Bowl guard (metal)	SM 10
Fully-automatic drain	65/0-N

Main spare parts

Part	Part No.
Set of wearing parts	22.810.4
Filter element 50 μm	810.6.950
Sight dome, compl.	VZ 722
Pr. gauge G 1/4, $\varnothing 50 \text{ mm}$	
0 to 10 bar	206-D
0 to 16 bar	207-D